

## Datalogger (Model 8040)



Masibus Datalogger, Model 8040 is uniquely suitable for compactly configuring a data acquisition environment using a PC as a human interface. Model 8040 is available in two versions, a half 19" rack module that can acquire data from upto 48 channels, and an expandable full 19" rack module with a maximum of 112 channels. Both versions internally log and also transfer measured variable in real time to PC.

They are remotely controlled by the host computer through a set of commands and transmitted in a RS-485/RS232 network. The modular design also provides more flexibility in the system configuration.

The Datalogger system architecture includes a power supply card, CPU card with a built-in RS-232/RS-485 communication port, input and output cards.

Datalogger enables user to log the real time data with time stamping. One can select input channel number for log and print purpose with specified time interval from operator terminal keys or using Masibus mACplus software. Print on demand facility is also available. mACplus software works on windows platform and is used for datalogger configuration, calibration and retrieving logged data to PC.

Alternatively, operator terminal is used for local display, configuration and programming of datalogger. Operator terminal is equipped with 24 keys and uses 2x16 alphanumeric LCD screen as user display interface.

Model 8040 is much smaller and lighter than our previous model occupying significantly less space. It can provide high speed measurement having a scanning speed of 1 second for 112 channels. Provision for 8 channel DO module provides alarm signal to annunciate abnormal process condition. 4 alarm levels per channel can also be configured.

## Features

- 16 - 112 channel datalogger
- Scans 112 channel in 1 second
- Three concurrent serial com. ports
- One Centronics printer port
- 2 x 16 character LCD Operator display terminal
- Universal input for each channel-mix
- Channel to channel input isolation option
- 512K battery backed memory
- Host computer/ operator terminal programmable

8040

**masibus**  
Advanced Automation - Sure Solutions

53

# Datalogger (Model 8040)

8040

## TECHNICAL SPECIFICATION

### Mechanical Dimensions (when I/O modules are installed)

Half 19" rack system	Approximately 270(W) x 132.5(H) x 260(D)
Full 19" rack system	Approximately 482 (W) x 132.5(H) x 260(D)

### AC Power Supply

Rated Supply Voltage	90 to 260 VAC / 120 to 370V DC
Rated Supply Frequency	50/60 Hz 3%
Power Consumption	Less than 35 VA
Power Connection	3 pin terminal strip
Insulation Resistance	> 50 M Ω (between AC supply & earth)
Dielectric Strength	1.5KV AC for 60 seconds between AC supply & Earth.

### Normal Operating Condition

Ambient Temperature:	0 to 55 °C
Relative Humidity	5 to 90% RH (Non condensing)

## PLUGGABLE MODULES

### Standard Configuration & Module Specification

The Following Modules can be installed in a main rack to configure Data Acquisition System.

<b>SMPS Module</b>	85 to 264 VAC or 120 to 370V DC 50/60 Hz 3 % Supply Module
--------------------	---

### Analog Input Module

Non-Isolated Analog Input Module	Universal Input (E, J, K, T, B, R, S, RTD Pt 100 & Linear inputs) Configuration of each channel based on sensor types used
----------------------------------	--

Each Input Module consists of 16 channels

Measurement Range: Refer component specification for more details

### Isolated Analog Input Module (optional)

300 V DC isolation between channel to channel

Universal Input  
(E, J, K, T, B, R, S, RTD Pt 100 & Linear input)

Configuration of each channel based on sensor types used

Each Input Module consists of 16 channels

Measurement Range: Refer component specification for more details

## CPU MODULE

### Isolated Communication Port for Host Computer

	RS232 / RS485 isolated communication RS232 isolated communication another port also available
Protocol	Modbus RTU
Baud-rate	2400,4800,9600,19200 (programmable)
Distance	Up to 20m for RS232 and 1.2Km for RS485
Connector	9 pin female D type

### Isolated Communication Port for Operating Terminal

	RS422 communication
Protocol	Modbus RTU
Baud-rate	19200 bps
Distance	Up to 20m
Connector	RJ45 connector

### Centronics Printer interfacing Port

	Parallel port interfacing
Protocol	Parallel Printer protocol

## CPU MODULE

Print period	Settable in Hours and Minutes OR Print on demand, separate key available as "PRN" facilitates the user to print the required channel on its invoking, irrespective of print period
Print channel selection	Any channel can be dumped to the printer
Print on Alarm	User Selectable
Connector	25 pin D type Vertical printing format (fixed)

### Memory

Memory Capacity	512KB Non-Volatile RAM with battery back-up
Real Time Clock	Provided
Data Save	For measured value with time stamping
Logging Period	In Hours: Minutes: Seconds
Data log Format	With decimal
Channel Selection	Any Channel can be configured for data logging. OR Data Logging on demand, separate key available as "DATA LOGGING" facilitates the user to log the required channel data on its invoking.
Logging Start Stop	Enabled through Key pad
Log Data Printing	Available for logged records
Downloading facility	Through MAC-plus software using Modbus protocol on excel format

### Alarm Module

Relay output module or Open collector module or Alarm Indication Module can be used as Alarm Module

Set point type can be configured for either 2 or 4 set points

2 Set-point configuration	High Very High (H-VH) Very Low - Low (VL-L) Low - High (L-H)
4 Set-point configuration	Very Low - Low - High - Very High (VL-L-H-VH)

## OPEN COLLECTOR OUTPUT MODULE

16 common open collector output is provided with this module. (With the same functions as provided with relay output module)

Open Collector Logic Type	Sinking Logic
Potential Wetting	External
Wetting Voltage Rating	24V DC @ 100mA

Connector: o/c interface: 25 pin type female connector.

Application: Any o/p can be mapped to any channel for alarm

# Datalogger (Model 8040)

## TYPES & NUMBER OF MODULES THAT CAN BE PLUGGED

Total 5 modules can be installed in half 19" rack system & 9 module can be installed in full 19" rack system. Out of total modules, power supply module & CPU module is required with each system. Other modules can be as per requirement.

Maximum 2 modules of Relay module or open collector module possible per system.

One Module of Alarm Indication possible per system.

## INPUT MODULE SPECIFICATION

### Thermocouple Inputs

Types	E, J, K, T, B, R, S
Cold-junction error	±2 °C maximum, 0 to 55 °C
Resolution	1°C
Accuracy	±(0.1% of Full Scale + 1 digit)
Temperature range	See table 1
Input Impedance	> 2 MΩ
Cold junction compensation	0 to 55 °C
Open thermocouple indication	"Open" displayed

### RTD Inputs

Types	Pt-100, 3 wire
Resolution	0.1°C
Accuracy	±(0.1% of Full Scale + 1 digit)
Temperature range	-200 to 850
3 Wire compensation	Using Hardware Technique
Open RTD indication	"Open" displayed

### Voltage & Current Input

Type	0 to 5V, 1 to 5 V, 4 to 20 mA & 0 to 20 mA (Resistor 250 ohms required for current i/p)
Scale range	-19000 to + 19000
Resolution	1 count
Accuracy	±(0.1% of Full Scale + 1 digit)

Table 1

### Operating Range

Type	Range	Resolution
E	-200°C to +1000°C (fixed)	1°C
J	-200°C to +760°C (fixed)	1°C
K	-200°C to +1350°C (fixed)	1°C
T	-200°C to +400°C (fixed)	1°C
B	+450°C to 1750°C (fixed)	1°C
R	0°C to +1750°C (fixed)	1°C

Table 1 (Cont.)

S	0°C to +1750°C (fixed)	1°C
RTD	-200°C to 850°C (fixed)	0.1°C
0 to 5V	-19000 to 19000	1 count
1 to 5V	-19000 to 19000	1 count
4 to 20mA	-19000 to 19000	1 count
0 to 20mA	-19000 to 19000	1 count

- Open sensor upscale/downscale feature for all inputs.
- One shot Calibration for all inputs through front key pad.

## OPERATOR TERMINAL MODULE SPECIFICATION

**Mechanical Dimensions** 96(H) x 192 (W) x 45(D) (all in mm)

### Operating Power

Rated Supply Voltage	24V DC
Power Supply capacity	10VA or less
Power Connector	2 terminal Strip

### Ambient Conditions

Ambient Temperature	0 to 55 °C
Relative Humidity	0 to 90% (non condensing)

### Display

16 x 2 large character LCD display (LCD screen with back-light)

Engineering units Upto 50 engineering units to select from list

### Keypad

Number of keys	24 keys with membrane keypad
12 Numeric keys	Used for inputting Numerical Value
4 Arrow keys	Used to select the required numerical value input field when there is more than one on the screen
3 Menu Keys	Used to Select/ Enter/ Escape menu items
5 Function Keys	Used for various functional operation

### Mode & Alarm LED

Power ON LED to indicate unit is in ON condition  
 4 Alarm LEDs for alarm indication & 1 Fault LED for Fault indication in the system  
 5 Mode LEDs used while programming/ calibrating/ verifying various parameters

### Storage Memory

In-built 2K Bytes EEPROM to store various parameters

### Communication

Communication Interface	RS422, 4 wire full duplex communication
Baud Rate	Fixed 19200 bps
Connector	Straight RJ 45 PCB mounted
Protocol	MODBUS RTU

# Datalogger (Model 8040)

8040

## Internal system architecture

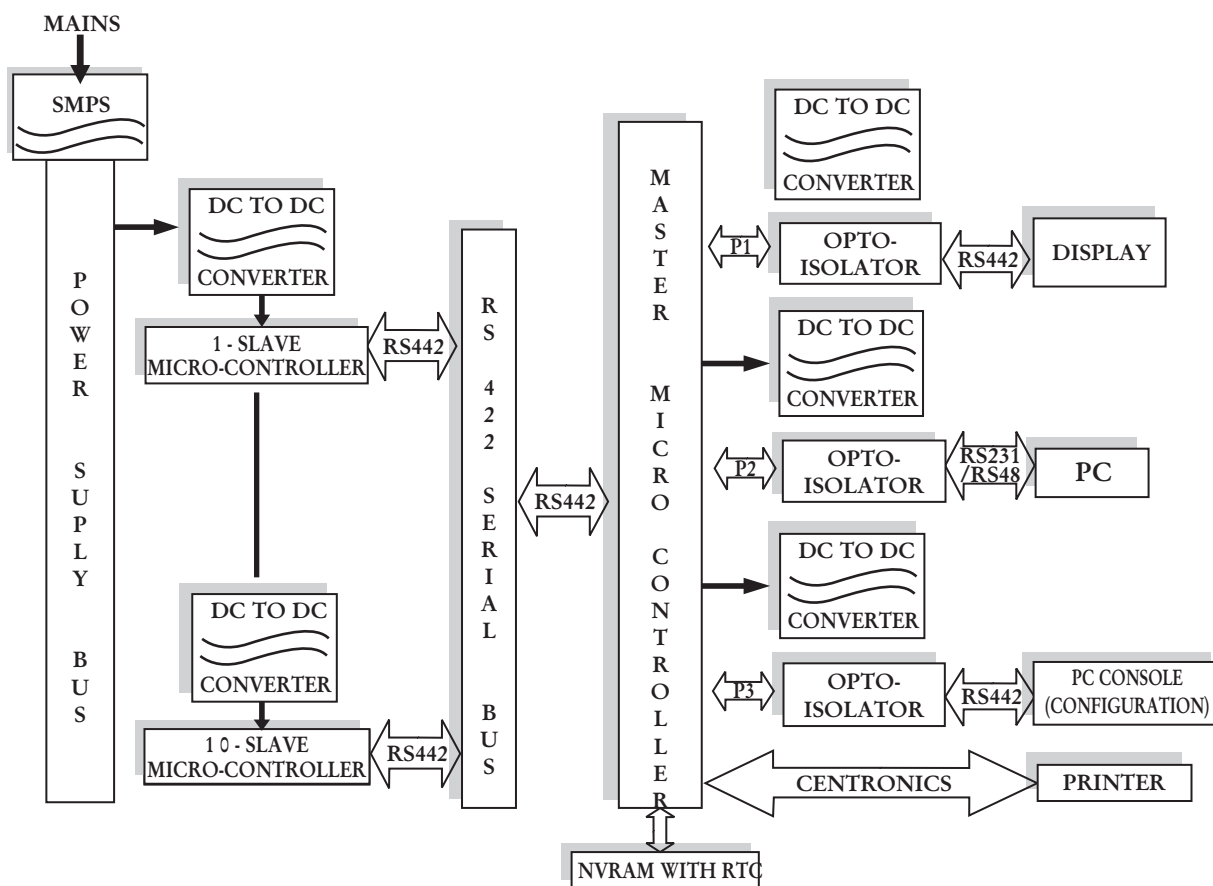

## ORDERING CODE

Model	No of Input	Input type/Configuration			Operator Terminal		Aux Output		Signal Termination		
<b>8040</b>	X	X	X	X	X	X	X	X	X	X	
A	Sixteen	N	Non Isolated	1	E	N	No	N	None	N	None
B	Thirty Two	I	Isolated	2	J	1	Separate	1	Relay card	1	Pre-fab cable
C	Forty Eight			3	K	2	Compact ▲	2	OC card	2	Pre-fab cable with DIN terminal module
D	Sixty Four			4	T					3	Terminals on chassis*
E	Eighty			5	B						
F	96			6	R						
G	112			7	S						
				9	Pt-100, 3W						
				C	4-20mA						
				D	0-20mA						
				E	1-5VDC						
				F	0-5VDC						

\* Terminal can be offered on back of chassis, available upto 64 channels only.  
O/T as separate  
▲ Datalogger chassis height will be 6U.

X - Specify from table